

PI MOTORSPORTS 2020 RULES

Table of Contents

Organization	Page 2
Membership	Page 3
Classes	Page 4
Weight Class	Page 4
Points System	Page 4
General Rules	Page 5
Super Stock Trucks	Page 11
Modified 4X4 Trucks	Page 15
Mixed	Page 20
Open Stock 4X4 Trucks	Page 21
Super Farm Tractors	Page 24
Pro Farm Tractors	Page 26
Hot Farm 466 Tractors	Page 28
Diesel 2.5/2.6 Trucks	Page 32

PI MOTORSPORTS INCORPORATED

PI Motorsports is a truck and tractor pulling motorsport located generally in the Wisconsin and upper Illinois area. It started in 1985 with Super Stock Trucks and Modified 4x4 truck vehicles and membership has increased ten-fold and now has eight classes.

PI MOTORSPORTS EXECUTIVE BOARD

There will be 11 members on the Board of Directors.

1. All Board members are able to vote at all times.
2. All Board members representing one of the 8 classes will serve a 2-year term. The office of President, Vice President and Secretary/Treasurer will be a 4-year term.
3. One-year term on tech officials.
4. Fiscal year runs from February 1 to January 31.
5. The board positions of President, Vice President and Secretary/Treasurer will be elected by the voting members at the Annual General Meeting.
6. All board members allowed one vehicle membership only at no cost plus \$50.00 insurance fee.

PI MOTORSPORTS MEMBERSHIP

1. All members (except Executive Board Members) are required to pay \$100 annual fee or \$125 after January 31 of the pulling year.
2. All pullers, including Executive Board Members, must pay \$50 insurance fee before their first hook.
3. Signing of all contracts must be handled through a board member only.
4. To vote at a year-end meeting, you must be the paid member of the pulling vehicle that you are voting for. Only one vote per membership vehicle. Pulling vehicle and paid member must have made at least one hook during the voting pulling season. Alternate and associate members are not voting members.
5. When voting at the year-end meeting, a written proxy vote from the paid member of the pulling vehicle in the class is allowed if it is given to the meeting leader prior to voting. Text messages on a cell phone will not be allowed as a proxy vote. Proxy vote must specify the paid member's vote or give the voting rights to a specified person. At any meeting (general or class), if there is a tie vote, the rule automatically does not pass. There is not a revote the same year. The rule can be voted on again the following year if on the agenda. It does not have to wait the three years.
6. ALL CLASSES: If a non-member puller shows up at a Pullers Inc. Show, they may join Puller's Inc., pay \$125 annual member fee plus \$50 insurance fee prior to registration. Or they may pay a \$50 per hook fee and run with their respected class for money but no points. Or they may pay a \$50 per hook fee and run for exhibition only (pullers that don't meet all class rules). All non-member pullers must meet *ALL* of the rules of the class before being allowed to pull. Exhibition pullers will pull before or after their respected class and will not be part of a pull off. No money will be paid to a non-member without a completed registration form and the collection of the \$50 fee prior to pulling. If a non-member pays a \$50 hook fee, they may opt to apply that amount towards a full membership. Points do not accumulate until a full membership is paid. Per hook pulls, prior to the payment of the full membership will not count for points. Members may use the per hook fee if they meet the rules of the class.

- All drivers must be at least 16 years of age and any driver between the ages of 16 and 18 must have a signed parental consent on file with the president.

PI MOTORSPORTS CLASSES

We have eight classes of vehicles in the P.I. Inc group. They are Modified 4 x 4 Trucks, Super Stock Trucks, Mixed, Open Stock 4X4 Trucks, Super Farm Tractors, Hot Farm 466 Tractors, Pro Farm Tractors and Diesel 2.5/2.6 Trucks.

PI MOTORSPORTS MAX WEIGHT CLASSES

Modified 4 x 4 Trucks	6,200	lbs
Super Stock Trucks	6,200	lbs
Mixed	6,500	lbs
Open Stock 4X4 Trucks	6,200	lbs
Super Farm Tractors	9,300	lbs
Pro Farm Tractors	11,000	lbs See page 27/others
Hot Farm 466 Tractors	9,500	lbs Cut Tires/no top cut
Hot Farm 466 Tractors	10,000	lbs Uncut / top cut tires
Diesel 2.5/2.6 Trucks	8,000	lbs

PI MOTORSPORTS POINTS SYSTEM

Points awarded to pulling vehicle:

15 points for 1st place, 14 points for 2nd, 13 points for 3rd, 12 points for 4th, 11 points for 5th, 10 points for 6th, 9 points for 7th, 8 points for 8th, 7 points for 9th, 6 points for 10th, 5 points for 11^h, 4 points for 12th, 3 points for 13th, 2 points for 14th, 1 point for 15th place, and 1 point after 15th place.

- A tie at a pull, vehicles split the point.
(7th and 8th place would each receive 8.5 points.)
- If you legitimately break while attempting to move the pulling sled, you will receive last place points and last place money. No points or money if you do not hook up to the sled on your own power. Except in a pull off. See pull off rules.
- Tiebreaker for yearend point's awards will be determined by the truck/tractor that goes to the most pulls. If there is still a tie at this determination, the breaker points will be calculated by the most 1st, 2nd, etc. places the puller took.

PI Motorsports Points System Continued

4. The top three points finishers in each class will be given a coat at the end of the year awards banquet.
5. End of year points payout will go to all paid members who pulled at least 50% of the class hooks (rounded down) based on a calculation of funds available and number of points earned during the season.

PI MOTORSPORTS GENERAL RULES

GENERAL RULES APPLY TO ALL CLASSES

New or rules changes for 2020 in bold

1. The rules must be complied with by all vehicles competing in Pullers Inc. Sanctioned event. There will be no grace period. You will be unable to pull until infraction is taken care of.
2. If Pullers Inc. is running the show that includes other classes, the other classes will follow Pullers Inc. rules.
3. Drivers and pitman, ****NO DRINKING**** allowed before your vehicle is done pulling. Track helpers and officials NO DRINKING until the show is finished.
4. Any major rule change will be effective for three years unless a safety issue arises.
5. All vehicles must have a tech inspection before they will be allowed to pull. Vehicles will only be teched up to one hour before show time. Tech officials are not required to tech a pulling vehicle other than at a pull. If a driver is requesting a tech official to tech a vehicle other than at a pull, a convenience fee for travel and time payable to the tech official should be negotiated between the puller and tech prior to the appointment.
6. Points and or money will be withheld from any competitor who fails to display the Puller's Inc Tech Decal on the Pulling vehicle.
7. There will be a mandatory driver's meeting before every pull. There must be a representative from each truck/tractor present at the meeting.
8. Numbering system on vehicles for lineup is in effect.
9. When drawing for a pull position, if one member has two vehicles in the same class they must declare which vehicle they are picking the number for BEFORE they pick that number. You are to only draw one number at a time.

General Rules Continued

10. There will be a \$20 late charge if you sign up at registration after ½ hour prior to start of show unless you notify one of the board members that you will be late. You will be required to pay at time of registration.
11. Three-minute time limit for "call to track" verified by track officials.
12. You must hook in order of registration to qualify for points and money. If you legitimately break prior to hooking, you will be allowed to repair and still compete as long as you come into line as soon as repairs are done and class is still pulling.
13. If arriving late to the show, no competitor may compete in his/her class if the class has already started and the vehicle has not been pre-registered.
14. All vehicles must have a working reverse and able to back up to the sled.
15. The test puller has the option to come back right away or in last position. Test puller may re-pull if vehicle goes out of bounds anywhere between 0-300'. Please remember to keep safety in mind for both yourself and others if this happens.
16. The test puller must make a measurable 100-foot hook attempt to be considered a test hook.
17. If leaving a pull after registering, you may come back, as long as you meet the three-minute rule.
18. If the sled is reset after more than one vehicle has pulled, the vehicles that have pulled, have the option of coming back right away without delaying the show, or in last position. Position will be determined by line-up person or PI board.
19. A pull off will immediately following the class unless otherwise determined by track official, board member or promoter.
20. In a pull off, you pull in the order you originally hooked. There is no dropping down in a pull off.
21. In a pull off, there is only one attempt.
22. In a pull off, a floating finish will be used unless the show director decides on the floating finish before the start of that class. Boundary lines will be extended endlessly.
23. There is a ten place pay out for Super Stock Trucks, Modified 4x4 Trucks, and Super Farm Tractors.

General Rules Continued

There is an eight place pay out for Pro Farm. There is a five place pay out for Mixed. There is a 7 place pay out for Diesel 2.5/2.6 Trucks and Hot Farm 466 Tractors. Open Stock Trucks is 6 places. Any money left over from a class will be put into the general PI account.

24. A tie at a pull, vehicles split the cash and points award equally.
25. If a class makes a show, but not a fair pull, (vehicles couldn't stop the sled, etc.), each vehicle that attempts to move the sled will receive 10 points and split the money evenly.
26. A rain out is considered, if the pull is cancelled within one hour of the show start. If there is a rain out you will receive 10 points if member and vehicle are in attendance and registered. 100% of entry must pull for complete class, if not, 10 points per vehicle, split purse money evenly.
27. Any notification to a board member over one hour prior to start time will be considered a cancellation, no points or money.
28. If there is a scale at the pull, vehicle and driver must weigh in for each class. No exceptions. The first time vehicle and driver are weighed in, it will be certified. If the scale at subsequent pulls is defective or there isn't one available, certification will be in effect. In the event of a broken scale the P.I. officials have the final decision.
29. Track official's decision will be final.
30. Protests must be filed in writing by any pulling member of the same class and given to a Puller's Inc. official, board member or tech official within 10 minutes after a class is over.
31. If a protest is filed in writing to a Pullers Inc official, board member or tech official at an event, protested vehicle/driver will immediately be notified as to the protest. At that point, the pulling vehicle and the driver must remain at the event to determine the results of the protest. If the pulling vehicle and, or driver leave the event before being teched under protest, the pulling vehicle and driver may be suspended from Pullers Inc. for 1 year and 10 days.

General Rules Continued

- 32.If a PI member of the same class wants to protest, the protester puts up \$500 and the vehicle being protested puts up \$500 before being tested. The protest fee of \$1000 is split between the protested and Puller's Inc if not found guilty. If found guilty, the \$1000 is split between the protester and Puller's Inc.
- 33.If there is any discrepancy in the sled operation, there will be a meeting of the pullers after the show.
- 34.No one is allowed on the track once the pulling vehicle is under green flag except for the flag person(s).
- 35.The seat belts must be in the pulling vehicle and are strongly suggested to be worn.
- 36.SEMA approved helmets and fire jacket must be on before vehicle reaches the track and stay on until their pull is done. Professional appearance only, no shorts.
- 37.A 2 ½ lb. fire extinguisher with gauge is required. This must be mounted in the cab, in working order and easily accessible to the driver.
- 38.When a vehicle has completed its pull, you must pull the vehicle off the track as not to interfere with the next pulling vehicle. If judgment of the P.I. Board and/or flag Person determine a puller has placed his or her vehicle as to interfere with the next vehicle, the vehicle/puller can be disqualified from the next event.
- 39.Pulling vehicle is the competitor only. (Trucks, Tractor) Pulling sled is not considered.
- 40.Disqualification, any puller and vehicle that violates a major rule or violates a rule repeatedly will upon decision of Puller Inc. official be disqualified for one year and ten days.
- 41.Disqualification, any competitor or member of his or her crew who exhibits unprofessional or un-sportsmen like conduct including language and or physical action toward event official, fellow competitors or spectators and delay the event will be disqualified from that event.
- 42.Disqualification, any vehicle that loses ballast weight, or loses safety equipment or failure of safety equipment to function while competing while being hooked to the pulling sled, will be a disqualification for the vehicle.

General Rules Continued

43. Disqualification, any part of the pulling vehicle that leaves course boundaries will be disqualified unless they have made a clear attempt to stop before the 100' line. After the 100' line they will be disqualified if any part of the vehicle leave the course boundaries.
44. Disqualification, while at a Pullers Inc. show, if the engine in a pulling vehicle is running, there must be a competent driver in the driver's seat at all times or the vehicle will be disqualified.
45. Disqualification, while at a Puller's Inc. show, if the pulling vehicle is in motion, the driver is the only person allowed in/on the pulling vehicle. Absolutely no riders in the pits or on the track or the vehicle will be disqualified.
46. Disqualification, any device used to raise hitch height while pulling.
47. Disqualification, if there is a DQ while competing while hooked to the pulling sled in a class, you will receive last place points and last place money. More than one DQ, split points and money. If you are disqualified off track for any reason, no points, no money.
48. If you legitimately break while attempting to move the pulling sled, you will receive last place points and last place money. No points or money if you do not hook up to the sled on your own power. Except in a pull off.
49. No portion of vehicle may interfere with sled chain or hook. Area 6" wide and 12" immediately above the drawbar must be free of all obstruction.
50. All vehicles must have tow hooks on the front of the vehicle with a minimum 2" opening.
51. Any ignition type engines must have kill switch checked while engine is running.
52. All vehicles must have a disconnect on the battery. It must be easily accessible. Recommended for Diesel 2.5/2.6 Class but not required.
53. All safety kill switches must be secure to something solid with a zip tie. 15# rating.
54. If kill switch or air shut off comes out not due to sled pulling it out, pull stands, no re-pull unless first hook.

General Rules Continued

55. Kill switch or air shut off location to read 18-36" above hitch for trucks and 48" above for tractors and allow up to 6" off center. No tape to inhibit pulling switch. Kill switch can't be attached to hitch in any way. They will be checked at every event. Remember to keep safety in mind for both yourself and others if this happens.
56. Pulling vehicles must have a neutral safety switch that will prevent the vehicle from being started while in gear. A reverse light in the dash and at the back of the vehicle must be illuminated while the vehicle is in reverse. Automatics will start in park only with neutral light on.
57. All weights must not extend forward more than 60" from the centerline of the front axle. No weight in cab or under hood unless securely fastened. Loose ballast sandbags, etc. are not allowed.
58. Drawbar must be equipped with steel hitching device no more than 1 1/8" thick and no less than 3/4" thick and must have a 3" opening. Suggestion Only: Draw bar steel hitching device to be tear drop shaped of 3-3/4" long by 3" width with max of 3-3/4" round.
59. Hitch must be rigid in all directions and solidly mounted to the vehicle frame and can't raise during the pull.
60. All vehicles must have a working rear brake capable of sliding the rear tires.
61. Pulling point can be no more than 1 1/2" from back edge of hitching device.
62. No clevis, chain, or cable allowed in hitching device.
63. No air pressure to be altered after drawbar is measured.
64. All vehicles are to have vertical bumpers at the rear most part of vehicle to prevent from passing over buckboard, up the sled, while backing up to hook or unhook. Bumper to be a minimum of 24" from the ground. Bumpers to extend a minimum of 8" vertically. Bumper must be of rigid construction.
65. Techs will not have to pay to pump a vehicle.
66. Random pump check at least once during pulling season.
67. Sled can be repositioned. Driver or appointed person by the driver can move the cone or stand in place before the sled is back to starting point. 2018

Section II- Individual Class Rules

SUPER STOCK TRUCKS

BODY

- 1.The pickup truck must have a factory wheelbase with factory steel pickup box, cab and fenders. May use plastic box liners or custom covers securely fastened. All drive train components must be in original position on frame except transfer case.
- 2.Trucks must run full hood and be in closed position while pulling. Tilt front ends allowed with grilles in original position. Front and rear bumpers optional. No one-piece fiberglass bodies allowed. Fiberglass body components are allowed. No carbon fiber. Must have front and rear glass.
- 3.Any hood scoop allowed. Base of carburetor must be below hood line. Air cleaner may protrude thru hood with maximum of 4" sides front and rear. 2018
- 4.All pickups in a class must have grille in and in original position.
- 5.If original vehicle has doors, they must be on & closed while pulling. Drivers door must open from inside and out.
- 6.Front and back glass or Plexiglas required on trucks. Driver must be visible front, back, and side. Factory tint on windows is allowed.
- 7.All trucks must have a high back seat.
- 8.All classes will be required to use only automotive type front and rear axle housings.
- 9.Trucks must have complete firewall and be securely attached while hooked. Composition must stop airflow and be fire retardant.
- 10.All lift bodies must have a safety stop.
- 11.Any type of 1/16" metal shield to cover all axle bolts are mandatory and they must be securely held in place.
- 12.No mud flaps or dirt deflectors lower than fenders.

Engine

1. Engine can't have a displacement larger than 530 CI.
2. Engine and truck must be made by the same manufacturer, heads must be factory production type heads with stock type valve train available. Except Fords A460 type cylinder heads allowed. No C460 type cylinder heads. No spread port heads.

SUPER STOCK TRUCKS / ENGINE CONTINUED

3. All engines to be naturally aspirated with a single 4 barrel carburetor with any stock configuration intake manifold. Gasoline fuel only. Electric fuel pumps allowed and any ignition may be used.
4. Headers and open exhaust allowed to run upright or toward rear of truck parallel to frame.
5. Aftermarket cast iron block allowed, but must be original OEM. Dodge aluminum wedge block allowed due to lack of availability Of OEM cast iron blocks.
6. On pressure side of fuel system, must have braided line.
7. Engine can't have a displacement larger than 530(+or-5) Maximum of 535 in.
8. At each pull, one truck out of 10 may be pumped.
9. Four-wheel drive pickups and vans only with automotive type V8, V6, or V4 cylinder engines.
10. Engine must be in engine compartment. All engine components including pumps, drives and harmonic balancers, must be behind the grille, in original grille position. Engine location is to be no less than 14" from the center of the front axle to rear of engine block.
11. Fuels: Pump gasoline, pump gasohol only. No high performance enhancing additive, no nitrous oxide allowed.
12. Fuel tank cannot be inside of cab unless factory installed in stock location. Otherwise it must be in box or in front of grille.
14. Fuel line must be encased in steel if inside frame rail and secured, or outside of frame rail in the clutch and transmission area.
15. All fuel pumps must stop when kill switch(es) are pulled.
16. Engine shields have a 1/4" steel shield 1" wide, 360 degrees around harmonic balancer, water pump may be used, SFI excluded. Must have straps 1/4"x 1" that will keep harmonic balancer from working forward.
17. Engine driven fan must have shroud 1/16" minimum 360 degrees around fan. Shroud no more than 1" from radiator and no less than 1/4" past edge of fan blades.
18. All trucks must have .060" steel or aluminum engine side shields present that extend from the bottom of the cylinder to the top of the frame rail.

SUPER STOCK TRUCKS / DRIVE TRAIN CONTINUED

Drive Train

1. Must be 1 transmission/1 transmission case or a combination of the two to be a piece.
2. Brakes must slide all four wheels.
3. All driveline brakes must be shielded 360degrees around it with 1/8" steel or 1/4" aluminum. The caliper may be used as part of the shield.
4. Any SFI approved clutch housing, flywheel pressure plate, clutch disc must be used. All scatter shield bolts must be in place, the spacing of the bolts is yet to be determined.
5. Any stall converter may be used with automatic transmissions. Scatter blanket must cover 360 degrees around converter and valve body of SFI approved shield.
6. All chain driver transfer cases must have shields wider than chain and extend down to center of lower sprocket and must be made OD 1/8" steel or 1/4" aluminum.
7. Vehicles that have a shaft between the transmission and the transfer case need only 1 loop if that shaft is no more than 12" long and the loop is in the middle.
8. Loops minimum 3/4" x 1/8" or larger and not less than 6" from U-joint or if more than 2 loops are used, they must be evenly spaced. Maximum horizontal clearance 2", maximum vertical clearance 8".
9. No cable or chain loops.
10. All drive line U-joints are to be enclosed in 360 degrees shield 1/8" steel or 1/4" aluminum. All U-joint covers must be a minimum of 3" wide and a maximum of 2" clearance from U-joint. Shield should restrain any broken parts. Joint should not be visible from side, top, or bottom.
11. No traction control of any kind. Any puller and vehicle found in violation of this rule will be disqualified for one year and ten days.

SUPER STOCK TRUCKS / TIRES CONTINUED

Tires

1. Front and rear tires must track within centerline of each other.
2. Tires 1700 series DOT tires maximum only, maximum 10" rims measured inside bead to bead. Maximum tire height is 35". NO BAR TIRES. No alterations allowed.
3. Tires must have rubber compound contact between tires and ground.
4. No dual wheels or chains allowed. No studded tires allowed.
5. Machine cut sipped tires allowed.

Hitch

1. From the point of hitch to the centerline of the rear axle shall be no less than 27% on the wheelbase.
2. For measuring hitch distance from centerline of axle, there must be a 1"x 1"x ¼" thick tab and vehicle will have a hitch height of 26".
3. If the pickup bed is too long it must be cut to allow the hitch to be clear and visible for hook up.
4. High point of hitch can't exceed 26" before, during, or after the pull.
5. Trucks where drawbar height adjuster link is attached to rear differential housing, the attaching point must be at axle center line or below. The drawbar adjuster cannot attach to anything above center line of the rear axle. The adjuster can only go down and forward.
6. Hold up mounting pin or pivot point on bottom side of pulling hitch must be no more than a maximum of six inches from hook point.

Miscellaneous

1. Vehicle may jump from 1 class to another as long as it meets all specifications of both classes and is a paid member of both classes.

MODIFIED 4 X 4 TRUCKS

Body

1. Any factory produced steel bodied pickup or van up to 133" wheelbase OR any factory produced fiberglass body.
2. All vehicles must use steel frame, no aluminum or magnesium is allowed.
3. All open bodied modified vehicles must have a roll cage equipped with lap belt and shoulder harness.
4. All modified vehicles must have doors that work or an escape hatch. They also must have lap belts and shoulder harness.
5. The pickup truck must have a factory wheelbase with factory steel pickup box, cab and fenders. May use plastic box liners or custom covers securely fastened. All drive train components must be in original position on frame except transfer case.
6. Trucks must run full hood and be in closed position while pulling. Tilt front ends allowed with grilles in original position. Front and rear bumpers optional.
Fiberglass bodies allowed.
7. All pickups must have grille in and in original position.
8. Front and back glass or Plexiglas required on trucks. Driver must be visible front, back, and side.
Factory tint on windows is allowed.
9. All trucks must have a high back seat.
10. No mud flaps or dirt deflectors lower than fenders.
11. Trucks must have complete firewall and be securely attached while hooked. Composition must stop airflow and be fire retardant.
12. All lift bodies must have a safety stop.
13. Any type of 1/16" metal shield to cover all axle bolts are mandatory and they must be securely held in place.
14. No airline controls to driver compartment.

Engine-Naturally Aspirated

1. Four-wheel drive pickups and vans only with automotive type V8, V6, or V4 cylinder engines.
2. All pickups and vans must be naturally aspirated with single engine. No diesel engines.

MOD 4X4 TRUCKS / ENGINE-NATURALLY ASPIRATED

CONTINUED

3. Engine must be in engine compartment. All engine components including pumps, drives and harmonic balancers, must be behind the grille, in original grille position.
4. There will be a 650-cubic inch limit. One sparkplug per cylinder. No overhead cams will be allowed.
5. Engine can't have a displacement larger than 650 CI.
6. At each pull, one truck out of 10 will be pumped.
7. Fuels: Pump gasoline, pump gasohol and alcohol only.
8. No nitrous oxide allowed.
9. Fuel tank cannot be inside of cab unless factory installed in stock location. Otherwise it must be in box or in front of grille.
10. Fuel line must be encased in steel if inside frame rail and secured, or outside of frame rail in the clutch and transmission area.
11. All fuel pumps must stop when kill switch(es) are pulled.
12. Engine Shields, have a 1/4" steel shield 1" wide, 360 degrees around harmonic balancer where pump may be used, SFI excluded. Must have straps 1/4" x 1" that will keep harmonic balancer from working forward.
13. Engine driven fan must have shroud 1/16" minimum 360 degrees around fan. Shroud no more than 1" from radiator and no less than 1/4" past edge of fan blades.
14. All trucks must have .060" steel or aluminum engine side shields present that extend from the bottom of the cylinder to the top of the frame rail.

Engine-Blown

1. Engine limit to 540 Cubic inch.
2. Ignition allowed: Magnetos MSD 20 or Mallory Super Mag 5, and MSD 10AL. These are the maximum size allowed. Ignitions rated less than these ignitions are allowed.
3. The only cylinder heads allowed are: any head allowed in Super Stock 4X4 as of January 2009. Any new version of these heads with modification (such as valve angle, etc.) must be approved by membership. No hemi or four valve heads allowed. No 5" bore spacing blocks or heads.

MOD 4X4 TRUCKS / ENGINE-BLOWN CONTINUED

4. 8-71 blower roots type only. Cast rotors only. No high helix or front discharge type blower. 1 to 1 under blower drive ratio. Blower restraint required.
Set-back blowers are not allowed.
5. The only blower manifolds allowed for Chevy & Ford engines are Littlefield & BDS tall or short deck manifolds. Indy competition manifolds for Chrysler wedge style engines only. All other blower manifolds must be approved by membership. No inner coolers allowed. No sheet metal intakes. Must have pop-off plate or burst panel on intake.
6. Shield around blower belt must surround belt, except bottom of bottom pulley. Must be as wide as belt, must be minimum 16 gauge material, and must be securely fastened in a minimum of 3 places.
7. Port injection is not allowed. All fuel must go through blower. High speed lean out system will not be allowed.
8. Must have fuel shutoff.
9. A spacer between blower and injector is allowed-max. 4" tall. Both surfaces of spacer must be parallel with top of blower.
10. Enderly Bird Catcher or Enderly Big & Ugly with 4-3/8" butterflies are the only injection system allowed. No center blade is allowed in any injection system.
11. Engine rules are set for 5 years at start of 2010. These rules may be changed, but require majority approval vote by the PI Mod 4X4 membership.
12. Motors can be pumped for CI (vehicle owner must be present or have someone capable of removing the rocker arms assembly. Tech inspectors will not perform this task.)
13. All other rules will follow the Mod 4X4 rules listed.

Drive Train

1. Front and rear tires must track within centerline of each other.
2. Brakes must slide all four wheels.
3. All drive line brakes must be shielded 360 degrees around it with 1/8" steel or 1/4" aluminum. The caliper may be used as part of the shield.

MOD 4X4 TRUCKS / DRIVE TRAIN CONTINUED

4. Any SFI approved clutch housing, flywheel pressure plate, clutch disc must be used. All scatter shield bolts must be in place.
5. Any stall converter may be used with automatic transmissions. Scatter blanket must cover 360 degrees around converter and valve body of SFI approved shield.
6. All chain driver transfer cases must have shield wider than chain and extend down to center of lower sprocket and must be made OD 1/8" steel or 1/4" aluminum.
7. Vehicles that have a shaft between the transmission and the transfer case need only 1 loop if that shaft is no more than 12" long and the loop is in the middle.
8. Loops minimum 3/4" x 1/8" or larger and not less than 6" from U-joint or if more than 2 loops are used, they must be evenly spaced. Maximum horizontal clearance 2", maximum vertical clearance 8".
9. No cable or chain loops.
10. All drive line U-joints are to be enclosed in 360 degrees shield 1/8" steel or 1/4" aluminum. All U-joint covers must be a minimum of 3" wide and a maximum of 2" clearance from U-joint. Shield should restrain any broken parts. Joint should not be visible from side, top, or bottom.

Tires

1. Tires limited to size 18" tread width and 34" high.
2. Tires must have rubber compound contact between tires and ground.

Hitch

1. From the point of hitch to the centerline of the rear axle shall be no less than 30% on wheelbase.
2. Hold up mounting on bottom side of pulling hitch must be no more than a maximum of six inches from hook point.
3. For measuring hitch distance from centerline of axle, there must be a 1"x 1"x 1/4" thick tab and vehicle will have a hitch height of 26".
4. If the pickup bed is too long it must be cut to allow the hitch to be clear and visible for hook up.

MOD 4X4 TRUCKS / HITCH CONTINUED

5. High point of hitch can't exceed 26" before, during, or after the pull.
6. Specify drawbar, no portion to exceed 25-degree angle.
7. Trucks where drawbar height adjuster link is attached to rear differential housing, the attaching point must be at axle center line or below. The drawbar adjuster cannot attach to anything above center line of the rear axle. The adjuster can only go down and forward.
8. Hitch bar cannot be made shorter than 30% of wheelbase.
A 1 or 2 piece with a limiting tab on an adjustable hitch.

Miscellaneous

1. Vehicle may jump from one class to another in one event as long as it meets all specifications of both classes and is a paid member of both classes.
2. At the first pull, vehicles kill switch will be checked with engine running, after that a buzz box or test light may/will be used to test kill switch.

MIXED CLASS

GENERAL RULES OF MIXED CLASS

1. 6500 lb. weight limit.
2. Class open to all types of pulling vehicles (tractors or trucks).
3. Follow all sanctioned safety rules and regulations
4. Point and payout for members and money payout only for per hook pullers.
5. Qualification of any vehicle in this class is subject to tech discretion.
be enclosed. Engines and carburetors may be exposed.

OPEN STOCK 4X4 TRUCKS

BODY

1. Any year full size steel body on OEM frame. No stripping of truck: boxes, wheel wells, interior doors, windshield, windows must be intact.
2. Traction bars allowed on front and rear.
3. Factory steering or hydraulic steering allowed.
4. No alteration of wheelbase allowed. (Length or width)
5. Vehicle may use electric fans and water pumps.
6. Truck must have fully functional front brake system or drive line brake.
7. No mud flaps or dirt deflectors lower than fenders.
8. **Allow light weight hoods with up to 8" hood scoop. 2020**

Engine

1. Trucks must contain factory stock engine with 480 CI limit with 2 CI leeway. Engine naturally aspirated- no alcohol/no N.O.S.
2. Headers are allowed with 1 7/8" max primary tube.
3. Factory produced cast iron head allowed with verifiable numbers. Numbers will be checked at tech time. Owner is responsible to take it apart to show the number.
4. Any 3" exhaust muffler allowed.
5. Exhaust must end behind the cab.
6. Any single carburetor with 4150 base. Cast iron/aluminum intake manifold is allowed. No tunnel rams or Pro ram, etc.
7. Factory stock cooling and charging system, single fuel pump, battery and fuel tanks in stock location or metal fuel tank or cell mounted in box with steel or steel braided lines. Battery operated ignitions. Batteries allowed in box of truck. Batteries not allowed in in cab or ahead of front bumper.
8. All street vehicles must have a kill switch.
9. Engine location to be no less than 14" from center of front axle to rear of engine block.
10. Dry sump oil system allowed.
11. After-market cast iron blocks allowed.

OPEN STOCK 4X4 TRUCKS / DRIVE CONTINUED

Drive

1. Blocking of rear suspension is allowed. Must retain a minimum of 5 leaf springs. Suspension configuration must be stock for your make and model. Block must be bolted and removable.
2. Multiple shocks are allowed. Lower front shock mounts must be mounted within 6 inches of the center of front axle.
3. One transmission/one transfer case allowed, all components must be stock appearing. After market gears allowed.
4. All driveline brakes must be shielded 360 degrees around it with 1/8" steel or 1/4" aluminum. The caliper may be used as part of the shield. Drive shaft loops, scatter shields, scatter blankets are HIGHLY RECOMMENDED.
5. Vehicles must have drive shaft safety loops present.
6. Vehicle must have SFI approved bell housing and block saver plate.
7. Vehicle with automatic transmission must have safety blanket and strongly suggest running SFI flywheel.
8. Any truck over 133'' wheel base will not be more than 193'' overall from center of rear axle to front of weight bar but must stay with 36% hitch rule.

Hitch

1. Max hitch height 26".
2. Hitch must be attached to frame only.
3. Hitch must not protrude into box of truck; box must be intact.
4. No part of hitch angle shall be no more than 30 degrees. Rear hitch support can go up or down. If up, it must be as vertical as possible. If down, it must be below center of rear axle.
5. Hitch can be no less than 36% of wheelbase measured from center of back axle to point of hook.
6. The support point of pulling hitch must be no more than a maximum of 6" from hook point. Top or bottom hitch support.

OPEN STOCK 4X4 TRUCKS / WEIGHT CONTINUED

Weight

1. 6200 lb. max weight limit
2. Weight may be added to front of vehicle but may not be more than 60" from center of front axle.
3. Only thing to extend past front bumper is weight and weight bar. Any functional component of truck cannot be used as weight.

Tires

1. Max 10" rims, bead to bead.
2. No duallies allowed.
3. Maximum of 133" wheelbase for all 4-wheel trucks.
4. Machine sipped tires allowed.

Miscellaneous

1. Trucks must meet tech inspection to qualify for prize money.

SUPER FARM TRACTORS

BODY

1. All tractors must have fenders.
2. Engine side shields must be installed and be a minimum of .060" thickness steel or aluminum and be securely fastened to the tractor. They are to extend from the hood to the frame and be the entire length of the engine.
3. OEM ROPS or equivalent must be installed.
4. Frame connectors must hold the tractor together without bell housing.
5. No portion of vehicle may interfere with sled chain or hook. Area 6" wide and 12" immediately above the drawbar must be free of all obstruction.
6. Wheelie bars must extend beyond rear tires with squared off frame on rear of bars.

Engine

1. Must use original make engine with original make tractor.
2. 640 Cubic inch limit with a + or - of 1% variance. Deck plates allowed with a 5/8" maximum.
3. No aftermarket exhausts will be used on OEM cylinder heads. They must have casting numbers. PPL Rule: Intake manifold maximum inlet side of 3.75 measured on the outside diameter. One inlet pipe only.
4. Dead man's throttle spring return to close.
5. Must have a means of shutting off the air inlet supply from driver's seat.
6. Air shut off loop on rear of tractor.
7. Throttle must return to closed position when released.
8. No nitrous oxide allowed.
9. Fuel line must be encased in steel if inside frame rail and secured, or outside of frame rail in the clutch and transmission area.
10. No exposed turbo charges.

SUPER FARM TRACTORS / ENGINE CONTINUED

11. One turbo charger. Exhaust bolt pattern no larger than 2.750" x 3.5 ", or 69mm x 88mm. No altering of a housing to accommodate a smaller base. Inlet and outlet, no larger than 3" at the face of the wheel.
12. Exhaust pipes must have two 3/8" grade 5 bolts set within 1" and 90 degrees to each other in the exhaust.
13. 3inch exhaust outlet at face of wheel. No big foot.

Drive

1. Tractor must have a clutch housing safety blanket.
2. Torque converters, automatic shifts, etc. Will be permitted.

Tires

1. Maximum tire size of 24.5 x 32, 210" maximum circumference at 10 P.S.I. Maximum of 48 lugs. Double cut tires allowed.
2. No dual wheels or chains allowed. No studded tires allowed.

Hitch

1. Drawbar height of 20" maximum, drawbar length no shorter than 18" from center of rear axle to point of hook.

Weight

1. 9,300 lb. maximum weight limit.

PRO FARM TRACTORS

BODY

1. Stock appearing tractors - frame, front axle, chassis, fenders and sheet metal.
2. Steel flywheel and safety blanket required.
3. Wheelie bars must extend beyond rear tires with squared off frame on rear of bars.
4. Front and rear tires must track within centerline of each other.
5. Wheelbase is to be a max distance of 114" from center of rear axle to center of front axle. Overall length not to exceed 13' from center of rear axle to furthest point forward. Not including front tow hook.
6. Rops with seat belt required.
Roll cage with 5-point harness recommended.

Engine

1. Must use original make engine with original make tractor.
2. Diesel class only.
3. 3000 RPM with no more than one-one second-spike when hooked to sled.
4. 640 cubic inch limit with a plus or minus of 1% variance. Maximum of 1" deck plate allowed. 2019
5. Stock head, block, intake and exhaust manifolds for that model engine or series engine.
6. Water injection is allowed with lubricant.
Random water samples will be checked. Illegal water is grounds for disqualification. Tractors required to add a drain valve or petcock to take a test water sample from the water injection system. Have the valve tee into the same line that feed the water injection pump. If the valve is mounted in a remote location with a hose or line, be able to show tech official the line came from the same line that feeds the pump.
7. Throttle must return to closed position when released.
8. Dead man's throttle - spring mounted on injection pump.
9. Air shut-off required on rear of tractor.
10. Must have a means of shutting off the air inlet supply from driver's seat.

PRO FARM TRACTORS / ENGINE CONTINUED

11. Only one turbo charger allowed. Inlet side up to 2.75" can be slotted and over 2.75" up to 3" max must be smooth bore with no slots or map rings. No removable slugs allowed on inlet side of turbocharger. Intake wheel must protrude into housing. No exposed turbo charger. Turbo size will be checked once a year and may be spot checked at any pull during the year.
12. P-pumps will be allowed.
13. Two 3/8 minimum cross bolts in exhaust pipe. Local puller may pull only once without above stated rule but the tractor must be stock rpm for that tractor.
14. Inner coolers allowed.
15. Must have a RPM monitoring device mounted to solid to tractor. It is the responsibility of the tractor owner/s to pay for their own cable and plug. It must be terminated next to the kill switch. Play back will be run at the end of each hook to verify RPM's. If RPM monitoring device does not work, only one grace period will be allowed per season.
16. No use of alternative fuels.
17. Tractor must be teched for cubic inch and pan bolts must be sealed by second hook of the tractor per year.

Tires

1. 20.8 x 38 max tire size or metric equivalent.

Hitch

1. Hitch height 20".
2. No 3rd link hitch support.

Weight

1. 11,000 lb. max weight limit - No cut tires and no intercooler
10,500 lb. max weight limit - Allowed either cut tires or intercooler
10,000 lb. max weight limit - Allowed both cut tires and Intercooler.

HOT FARM 466 TRACTORS

BODY

1. Stock appearing tractors- chassis, fenders, and sheet metal.
2. Tube frames and rack and pinion steering are allowed.
3. Steel flywheel and safety blanket required.
4. Wheelie bars must be able to support the weight of the tractor and extend 2'' beyond the radius of the rear tires with squared off frame on rear of bars and be no more than 10'' above the ground.
5. Wheelbase is to be a maximum distance of 114'' unless originally produced by manufacturer, at which point the wheelbase will remain stock. Overall length not to exceed 13' from center of rear axle to farthest point forward. Not including front tow hook.
6. Rops with seatbelt required, roll cage with 5-point harness recommended.
7. Side shields are required.
8. Wide front tires must ride in the track of the rear tires, no narrow front ends.
9. Ladder bars are required.
10. Homemade front ends allowed but will be subject to safety inspection by a Pullers Inc. tech official for approval, no running gear front ends.
11. Stock transmission or OEM replacement transmission must be externally stock appearing. Aftermarket gear boxes will be allowed.

ENGINE

1. Any engine with a maximum of 466ci with a plus or minus of 1% variance / no deck plates allowed.
2. All tractors will be pump tested for displacement and then the oil pan will be tagged and sealed, if this is not done before the first pull it must be completed before any prize money or points are awarded.

HOT FARM 466 TRACTORS / ENGINE CONTINUED

3. Testing of tractors will be done at each event. Three pullers will be chosen at random at the conclusion of registration by the registration person or head tech official. These 3 tractors will be tested for either water, turbo size or fuel immediately after the class is done pulling. Water must freeze consistently after 4 hours in the freezer against a clean standard sample. Fuel should not burn when ignited with a lighter. Turbo intake with a 3.050" slug. If any criteria are not met, puller is disqualified for that pull with no money or points awarded.
4. Tractors must have OEM cylinder head, intake manifold and exhaust manifold for that model series engine.
5. Intercooler, after coolers or any cooling devices for the air or fuel are not allowed.
6. P-pumps allowed (P 7100 max pump). Maximum pump size 13mm.
7. Only one turbo allowed. Turbo will be checked and certified and then sealed. 2019
8. Maximum turbo size of 3" inlet allowed, unlimited outlet size, slotted inlet covers allowed. Inlet wheel must protrude into the inlet housing, no slugs, steps in the inlet housing or slipped wheels are allowed, a map ring is permitted in stock location not to exceed .200".
9. *Diesel fuel or Bio-Diesel Only. Must have valve in line between tank and pump to be able to extract fuel sample for testing.*
10. Water injection is allowed with lubricant. Random water samples will be checked. Illegal water is grounds for disqualification. Tractors required to add a drain valve or petcock to take a test water sample from the water injection system. Have the valve tee into the same line that feeds the water injection pump. If the valve is mounted in a remote location with a hose or line, be able to show tech official the line came from the same line that feeds the pump.
11. No alcohol, propane or nitrous oxide injections.
12. RPM monitoring device is required on all tractors and must be mounted solid to the tractor and cannot contain any splicing in between the pickup at the front of the tractor and the plug in at the rear of the tractor. It is the tractor owner's

HOT FARM 466 TRACTORS / ENGINE ONTINUED

responsibility to pay for their own cable and plug. It must be terminated next to the air shut off cable. Play back will be run at the end of each hook to verify RPM's.

If RPM monitoring device does not work, only one grace period will be allowed per season.

Tractors pulled once <3000 RPM. Tractors pulled two or more times <3030 RPM.

13. Any tractors running with different clubs that may allow intercoolers will be subject to be inspected at every pull to verify intercooler is disconnected.
14. Air shut off is required on the rear of the tractor and must be mounted on same vertical plane as hitch point with a 2" diameter ring and will be tested before the first pull.
15. A means of shutting off the air inlet supply from the driver's seat is required.
16. A fuel dump valve is required.
17. Throttle must be spring loaded and return to idle position when released.
18. Exhaust pipe must have (2) 3/8 minimum cross bolts in the vertical portion of exhaust pipe, no rain caps or curved exhaust, must exit straight up.
19. Electric fans are mandatory for safety.
20. No headers or custom intake manifolds.
21. Data loggers are allowed.
22. Intake crossover pipe can't exceed 3.5" outside diameter. It can't have any cooling thin tube as part of it.

HITCH

1. Hitch height is 20" max as measured from the ground, hitching eye must be a minimum of 1" thickness with a 3" inside diameter hole.
2. No 3rd link hitch support.
3. No floating drawbars. Drawbars must be rigid in all directions.

TIRES

1. 20.8 x 42 maximum tire limit. Any cut tire allowed.

HOT FARM 466 TRACTORS / WEIGHT CONTINUED

WEIGHT

1. 9,500 max weight limit for tractors running any cut tires other than top cut.
2. 10,000 max weight for tractors running un-cut or top cut tires.
3. All tractors will cross the scale at every pull to line-up before the class starts.
4. All tractors will be certified at the first pull of the season. A three-tractor average will be used for future certification. Certified weights will be recorded by tech officials.

DIESEL 2.5/2.6 TRUCKS

BODY

1. The body must be the OEM truck body including the full bed floor. The body must retain full sheet metal. Metal aftermarket hoods are permitted. Fiberglass hoods and roll pans only are permitted. All fiberglass hoods must be shielded on the underneath side with sheet metal or aluminum skin a minimum of .060 thick. The hood must be closed and securely latched while the truck is hooked to the sled. The complete OEM firewall and complete OEM floor pan is mandatory. A factory installed pickup bed or commercial style aftermarket bed must be installed. **Flatbeds are prohibited. 2020**
2. **The use of hand -throttles is allowed. After market gauges are allowed. 2020**
3. Complete headlight and taillights assemblies are mandatory and must be operative, except the right front headlight may be removed for air inlet to engine. Complete OEM windshield and all other windows are mandatory. Windows must be able to operate per factory specifications. They must open and close via electrical or mechanical means.

ENGINE

1. **Batteries are not required to be in stock location. 2020**
2. Radiators must be in stock location and be of at least stock size.
3. **The engine block must have been available as a factory option on a one ton or smaller pickup truck. Cubic inch limit of 444CI. 2020**
4. All trucks must be equipped to direct exhaust upward. Two 3/8 diameter bots must be installed through exhaust pipe in a cross pattern within 1 inch of each other.
5. Fuel must be pump #1, #2 diesel or Soy/Biodiesel. Fuel must be commercially available. No additive.

DIESEL 2.5/2.6 TRUCKS/ ENGINE CONTINUED

6. The fuel injection pump is limited to cylinder number specific (I.e. 6-cylinder pump on a 6-cylinder motor). Dual high-pressure common rail fuel pumps or HPOPs are allowed. Ag governors permitted. No Sigma or 12 cylinder pumps allowed.
7. All engines turning more than 4500 RPM must be equipped with a harmonic balancer or dampener meeting SFI Spec 18.1.
8. Factory style or aftermarket air-to-air coolers allowed. No types of water to air coolers or spray bars allowed.
9. **A working kill switch and/or air shut off is required to be within one foot of hitch. Kill switch must shut off the fuel pump when pulled. It is recommended to have an air shut off.**

2020

10. Nitrous Oxide is prohibited. No other oxygen extenders are allowed. All system components must be removed from the truck.
11. Propane is prohibited. All system components must be removed from the truck.
12. Water injection is prohibited. All system components must be removed from truck.
13. **All turbo chargers will be banded once teched. 2020**
14. **Turbochargers 2.5 / 2.6:**

2.5 TURBOCHARGER:

T4 mounting flange is the largest allowed. Turbos must be a true 2.5 charger. No clipped wheels or step down covers. Billet compressor wheels are allowed. A single, 200 inch MWE groove is the maximum allowed. It must be in the neck of the inducer bore behind face of the wheel in the measured 2.5" area. Forward facing MWE grooves are not allowed. Inducer bore must be non-removable. All air must go through the 2.5 inducer bore and the .200" MWE groove. The bore must be 2.500" on both sides of the .200 wide MWE groove. The wheel must protrude into the 2.5 bore 1/8 inch. Turbo will be checked with a 2.550 plug or internal calipers. The 6.4 Power Stroke engine may utilize the factory twin turbo configuration with factory cast wheels. The driver will be responsible for making turbo accessible for tech personnel to measure and inspect.

DIESEL 2.5/2.6 TRUCKS/ ENGINE CONTINUED

In general:

- a. 2.5" bore (measured with a 2.550" plug) before and after the MWE
- b. All air must enter the 2,5" bore and/or the 0.200 MWE
- c. Wheel must protrude 1/8" into the 2.5" bore
- d. MWE must be a factory style, perpendicular to the turbo shaft entry into the 2.5" bore portion of the charger.

See photo below:

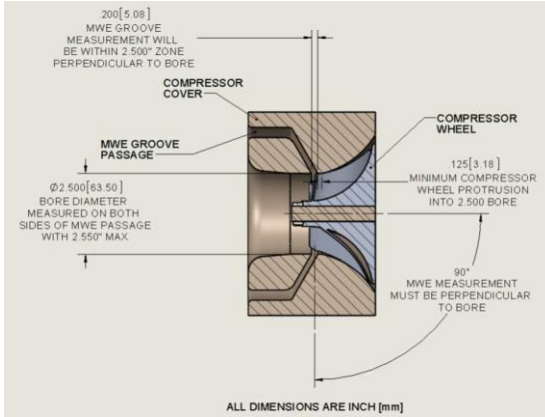

2.6 TURBOCHARGER:

Limited to 2.6" smooth bore inducer. No map width enhancement. Groove allowed. Compressor wheel must protrude into the 2.6" bore 1/8". Bore will be checked with a 2.605" turbo plug. Plug must not be able to enter inducer core and contact wheel. T-6 mounting flange is the largest allowed. **2020**

DRIVE

1. Working front hydraulic brakes are mandatory. Rear hydraulic Brakes are recommended. **2020**
2. The OEM chassis is mandatory. The engine must be in the OEM location for the body used. The vehicle must retain the OEM chassis. Wheel tubs, back half conversions, tube conversions, etc., are prohibited.
3. An OEM transmission and transfer case are mandatory. They must have been an option on a one ton or smaller pickup.

DIESEL 2.5/2.6 TRUCKS/ DRIVE CONTINUED

4. Non-OEM rear-end housings are prohibited. The rear end housings must have been for a one ton or smaller pickup. Outer rear axle bolts must be covered with a cap or shield.
5. **The vehicle does not need to retain the full, original OEM steering gear. 2020**
6. The factory suspension configuration must be retained. Modifications to the front suspension that would alter the original location (i.e. moving it forward or backward) are not permitted. Strut tower braces, lower tie bars, sway bars, and limit straps are permitted. Traction bars and devices are permitted. Air shocks are prohibited.
7. **An OEM style suspension is mandatory. Traction bars and devices are permitted, they must be bolt on only, and welds are permitted for attachment to the frame or axle housing. Traction bars if installed must have a chain or cable or some type of safety device mounted one (1) foot from the front support to catch the bar in case of failure. Control arms may be strengthened or replaced, providing all original mounting points are retained and used. Sway bars, lower tie bars, limit straps, and camber kits are permitted. Air bag spring assist and air shocks are prohibited. Rear suspension can be mounted solid. Leaf spring may be removed. 2020**
8. Non - OEM transfer cases are prohibited. It must have been an option on a one ton or smaller pick-up truck.
9. Transmission- Automatic: Non - OEM transmissions are prohibited. Aftermarket torque converters, valve bodies and internal components are permitted. Transmission brakes are prohibited. Any non - OEM floor mounted automatic shifter must be equipped with a spring-loaded positive reverse lockout device to prevent the shifter from accidentally being put into reverse. A functional neutral safety switch is mandatory. Vehicle must not start in gear. All transmission lines must be metallic or high pressure type hose. All vehicles using an

DIESEL 2.5/2.6 TRUCKS/ DRIVE CONTINUED

automatic transmission must be equipped with a flex plate meeting SFI Spec 29.1 if turning more than 4500 RPM. A blow proof transmission blanket is recommended.

10. Transmission-Manual: Non - OEM transmissions are prohibited. Aftermarket internal components are permitted. A clutch meeting minimum SFI Spec 1.1 or 2.1 is mandatory on all engines if turning more than 4500 RPM. All manual transmissions must be clutch assisted. Sequential shifters are prohibited. All transmissions or clutch pedals will have a safety interlock switch so that vehicle will not start in gear. A blow proof transmission blanket is recommended.
11. **The vehicle must retain the original factory wheel base and track width. Factory duals are allowed only with factory spec tires. Lengthening frame up to 158" is permitted. Longer trucks (158"-172") must maintain OEM measurements for body being used. 2020**
12. **All visible U-Joints must be shielded by ¼" steel or 3/8" thick aluminum tubing 6" long centered on U-Joint. 2020**

HITCH

1. Receiver or drawbar style hitch permitted.
 - a. RECEIVER STYLE. Reinforcements are permitted. Reinforcements must not extend forward of the center line of the rear axle and must remain inside the frame rails. The hooking point must be the rear most point on the vehicle and must be rearward of the stock location of the tailgate. The hitch must be horizontal to the ground and stationary in all directions. Bumper may be notched or removed. The hitch's height from the ground may not exceed 24 inches. The hooking point must have a minimum of 3 inch by 3 ¾ inch inside opening for the sled hook. The hooking point must be a minimum of 44 inches from the center of the rear axle, to the end of the hole where the hook touches metal to be pulled from, this is the hooking point.
 - b. DRAWBAR STYLE. Drawbar hitch must be stationary in all directions. Frame mount and forward mount can be no farther than centerline of rear axle. Hitch cannot

DIESEL 2.5/2.6 TRUCKS/ HITCH CONTINUED

exceed 25-degree angle from pivot point to hook point. No hitch supports or adjuster fasteners to rear axle housing shall be above center point of rear axle. Pivot pin of drawbar can be no further forward than the centerline of rear axle. Safety hitch mounted 12" below primary drawbar, minimum 3/8" thick. Hitch must have an opening of 3x3 3/4 for hook. Hooking point must be a minimum of 44" from the center of the rear axle and 24" from the ground. 2020

WEIGHT

1. 8,000lb maximum, with driver.
2. Ballast is permitted. Front hanging weights are allowed, not to exceed 60 inches forward of the center of the front axle. This will be measured from center of front axle to end of weight assembly. Ballast may be added in the bed of the truck but must be secured. No weight inside of the cab. Fuel cell and/or battery allowed in front weight box. 2020

TIRES

1. The tires must be DOT street tires. Cut tires are prohibited. 35x12.50 maximum Factory dually trucks are allowed but must be STOCK size tires for that year and model. No bolt on duals allowed.

MISCELLANEOUS

1. Helmet and an SFI 3.2a approved fire jacket are mandatory. 2020

